

THE CHIP PILE

THE NEWSLETTER OF THE CENTRAL TEXAS WOODTURNERS ASSOCIATION

CTWA Meetings

MARCH MEETING

Tuesday, March 15, 2005
7:00 - 9:00 PM
American YouthWorks - Austin, Texas
1901 East SH 71
(about 1/4 mile east of I-35 on south side of SH 71)

FIRST SATURDAY TURN OUT

Don't forget the First Saturday Turn Out at Charlie Collin's shop, 1603 Hydro Drive, Austin, the first Saturday of every month, from 9 - 12 AM. Turn west on Howard Lane off I-35, take the third right on Thermal Drive and the first left on Hydro Drive.

Spring Cleaning!

It's that time of the year again. Spring is in the air and those of us with unheated shops are more active. The doors are up and the chips are flying. I have been recycling my chips at a peach farm, where they are used as mulch.

All of the machines in my shop, except for the lathe, are on wheels, so it is easy to rearrange things and move them around. I have also hung counterweights on the drill press so that I don't have to strain as much moving the table up and down. My new motto is that aging is not for sissies. It also means that I have to

Next, I need to run my wooden lathe ways thru the jointer so the banjo will slide more easily. That also means fewer splinters in the tush from riding the lathe as I turn hollow forms.

Now I need to get rid of a squirrel cage air handler. It's free to the first person to call me at 402-0656. I deliver!!!

For sale, one antique water bath slow speed grinder with stand. \$50 or trade - now available.

Best of all I have been talking to a high school student about an apprenticeship this summer. I will try taking him to the AAW Symposium in Kansas City, since he can get in free. What a deal.

Fred Stidman



adapt my approach to the shop or else limit my activities. I already use larger handles on gouges and scrapers.

I have consolidated two older grinders into a new eight inch slow speed grinder. Sweet revenge; instead of my kids leaving things at my house to store, I now get to unload my excess stuff in their garage instead. I chuckle all the way home.

February Demo

Going to the Birds

Our demonstrator for February was Winter Texan and Hill Country Turners member **Steve Promo**. Steve entertained us with tales about his custom made LARGE lathe as well as how he got into birdhouses and was transformed into an *artiste*.

Steve began with a slide talk, first showing us various views of his lathe and the uses that he puts it to. A lot of folks tell you that their lathe is built like a tank, but this one really is. It weighs 2,300 pounds without accessories, thanks in large part to big hunk of one-inch armor plate salvaged from a tank plant scrap pile. It is also mounted on a base of Kevlar reinforced plastic, also from tank scrap. One of his projects involved turning a conference table, fourteen feet in diameter, accommodated by cutting a hole in the floor. ...and you're proud of being able to turn a 24 inch piece on your Oneway.

Steve then showed us examples

From the President's Shop

Inside

This Month's Program, page 5
Calendar, page 6
Volunteer Instructors, page 8
Membership Information, page 8
Classified Ads, page 11

The American Association of Woodturners is "dedicated to Providing Education, Information and Organization to Those Interested in Woodturning." In keeping with the standards of our National Organization, the Central Texas Woodturners Association hereby gives permission for all other woodturning chapters, organizations, magazines and newspapers to use any materials contained herein for the benefit of all woodturners everywhere. We ask that credit be given for the source of the material.

President

Fred Stidman
512.402.0656
f.stidman@earthlink.net

President Elect

Len Brissette
512.838.0584
mesquite@texas.net

Membership Chairman

Drew Shelton
ew.shelton@sematech.org
512.863.4651

Program Chairman

David Dick
thewoodwriter@yahoo.com
512.357.6517

Treasurer

Ed Roberts
512.255.3294
eroberts6@juno.com

Secretary/Newsletter Editor

Charlie Kay
512.295.2144
ckay@austin.rr.com

Webmaster

Larry Walrath
512.255.5379
larry@larrywalrath.com

Audio/Visual Coordinator

Frank Miller
512.335.4768
millerstexas@msn.com

Librarian

Marcia Tolly
512.858.4471
johntolly@austin.rr.com

CTWA Web Site
www.ctwa.org

Editorial Information

This newsletter is by and for members. The Editor welcomes any written materials and will provide assistance with getting your information into publishable form if you want. **DEADLINE IS THE FIRST MONDAY OF THE MONTH.** Contact me with your ideas and drafts by phone at 512.295.2144, by E-mail at ckay@austin.rr.com or mail them to:

THE CHIP PILE
c/o Charles Kay
100 Matzig Cove
Buda TX 78610-3108

of his various approaches to bird houses. These include staved or coopered, stack laminated and solid wood pieces.

The first birdhouse demonstrated was the stack laminated style. He began by preparing the box blank from a section of green log. He turned a cylinder between centers, with a stub tenon

for the chuck. After mounting the piece in the chuck, the exterior box profile is turned and the interior wall is marked on the end with a pencil with the lathe turning. The blank is then taken to the bandsaw and the core is cut out and the seam reglued. The roof section and the bottom are then turned with tenons so that they can be glued into place. After drilling and installing the

roof hook, the perch is turned and glued into place.

Steve then proceeded to demonstrate the turning of a solid round birdhouse. Once again, the process begins by

mounting a piece of log between centers, truing it and turning tenons on both ends. The blank is then mounted in the chuck, with tailstock support and retrued before turning the roof section profile and the box profile. About half the cylinder is left connecting the box to the chuck. The roof is chucked between centers with a steady and hollowed. Since the wood is green, it is necessary to bag the roof section when

the hollowing is done.

The box section is then hollowed, drilling out the center to depth, then gradually enlarging the box opening until it is a snug fit with the roof flange. The box section is then jammed onto the roof flange and tailstock support provided before turning the bottom profile. The house section can then be sanded, signed and sealed and bagged.

A perch is then turned and the entry hole, perch hole and hook hole are drilled. It is important



to size the house cavity and the entry hole for the bird species desired (**see sidebar**). The perch and hook are installed. The perch and hook are installed. The house can then be carved or textured if desired, before a UV resistant finish is applied.

Thanks, Steve, for an inspiring presentation. We expect to see some birdhouses showing up on our Show and Tell table in the *******

Sources

Different species of birds are very particular about the size of the entry hole and the size of the nest box. To size your house for the birds that you hope to attract, you can go to <http://www.fb-net.org/birdhouses.htm> to find those critical dimensions.

The bandsaw used by Steve in his demonstration was provided by Mini-Max, 2012 Centimeter Circle, Austin, TX 78758. They can be contacted at 866.975.9663 or at www.minimax-usa.com.

Bring Back Raffle

John Cole was the winner of a teacher's bell turned of white oak, blackwood and cherry by **Bob Duncan**. **John Cole** also took home a seed pot turned from mesquite and spalted pecan by **Len Brissette**. **Jim Brinkman** had the lucky ticket for a mesquite bowl turned by **Jim Whited**.

Jim will bring a turning to the next meeting. Since John Cole was a visitor, the officers will provide Bring Back items for him. These items should be representative of each person's best work.

It should be noted that the Bring Back Raffle is meant to be a fun event. No one is grading you on the quality of your work. Just bring a piece that represents the best that YOU can do. If

you don't have a lathe or feel like you have enough experience, contact one of our Volunteer Instructors to help you prepare a Bring Back piece. So buy a ticket and get involved. *******



Show and Tell

Our demonstrator, **Steve Promo** brought along a bowl and a serpentine form, both turned from Texas mountain laurel and finished with shellac, wax and 0000 steel wool.

Jack Besperka showed a platter turned from mesquite, with a textured rim. It was finished with Waterlox.

Larry Walrath shared three threaded lidded boxes, turned from spalted pecan.

Bill Hammack apparently thought he was back in school, as



he showed off a nice red apple of unknown wood finished with Mylands. He has to sit in the

corner, though, until he gets the proportions right.

Dave Dick displayed a spindle gouge handle turned from partly dyed curly maple and a "tire knocker" turned from ash and finished with Waterlox (actually, he first claimed it was a baseball bat, until we gave him a hard time about how heavy it was).



Charlie Kay brought two bowls, one of mesquite and one of pecan, finished with Minwax and the Beall



Craig Timmerman wowed us with three pieces: an off-center vase of mesquite and turquoise, "Suspension III," turned from a cedar elm burl and "The Torch," turned from a maple burl. All were finished with Deft.



System.

H. O. Evans found the glue pot again and shared a Southwestern bowl turned from 844 pieces of walnut, maple, redheart, bloodwood and purpleheart.



Jimmy Tolly showed off salt and pepper mills turned from mesquite and finished with teak



oil, as well as a maple and mesquite bowl, also finished with teak oil.



Show and Tell



Profiles

I am planning a new feature for **THE CHIP PILE**, using the **Profiles** tag line. In it, I want to feature a different CTWA member each month. I plan to spend some time on their woodworking and woodturning experience, what turnings they specialize in and what their other interests are. In order to simplify this a bit, I am developing a questionnaire that I will be sending via the E-mail mailing list. If each of you will fill that questionnaire out and get it back to me, I can get started. I know there are lots of good stories and lots of talented turners in our club, so I'll probably devise some way to pull the names out of the hat a random, so as not to favor any one turner over another. Look for the questionnaire in your E-mail box in the next week or so.

Charlie Kay



Wood Auction

Our February wood auction was a financial success, contributing \$269.00 to our lathe fund. Thanks to **Jimmy Tolly** for coordinating it. Special thanks also to **Dave Dick** and the late **Pat Brenny's** wife, **Barb**, for contributing much of the wood. Now if Jimmy just didn't throw out his bad back loading all of that wood into the back of his truck. Thanks to all who donated wood to the auction and to all who purchased some. We'll do this again later in the year.



March Program

Hollow Forms

This month's program will be by **Lyle Jamieson**. It will be a demonstration of his hollowing method, using the laser depth guide. If you have never seen one of Lyle's demonstrations, come prepared to see some interesting turning. He really makes it seem easy.

See y'all Tuesday.

Dave Dick



Business Meeting

There were 54 people at our February 15, 2005 meeting, including five visitors.

Mentoring New Brazos Valley Club

CTWA member and Belton resident James Norton is one of the organizing members of the Brazos Valley Woodturners, which will meet in the Temple area. They have asked us to assist them in getting started.

Membership Renewals

Any members who have not renewed their membership by the end March will be dropped from the rolls.

Jamieson Demonstrations

Stacey Hager reviewed plans for the Jamieson Sessions scheduled for the middle of March and Ho Evans collected money.

Wood Artisans Show

The President of the Woodworkers Club made a pitch for the upcoming Wood Artisans Show to be held at Penn Field. Entry blanks are available from Woodcraft.***

President's Challenge

Fred Stidman has put off the Presidents flower challenge until the April meeting. Last month we ran overtime and we would like to give Lyle Jamieson as much time as possible.

The Challenge is flowers, ...turned, carved, pyrographed, painted, dyed etc. Start thinking!

Web Site

You may want to check out the CTWA Web Site at www.CTWA.org. If you have comments, suggestions or something for the gallery, get in touch with Webmaster Larry Walrath at larry@larrywalrath.com.

On the Road

Here We Go Again!

It looks as if this feature is going to have to be renamed to Where Are the Tollys This Month?

It seems that Johnny and Marcia never stay at home anymore.

On February 10, Johnny and Marcia traveled over to Kerrville where Johnny demonstrated making houses for our feathered friends to the Hill Country Turners. Well, that is, ornamental bird-houses as some are so small that ladies can wear them as earrings. I guess that would make them Texas mosquito or fly houses. There were 42 people in attendance and everyone really enjoyed the demonstration. There were a number questions for Johnny after the demo.

This demo proved to be a fair swap, as the February CTWA demonstrator featured Hill Country Turner Steve Promo demonstrating how to make bird houses as well. Of course, Steve's bird-houses are much larger and real birds can use them. Johnny and Steve had never talked before hand. Guess February must be birdhouse month.

Marcia and Johnny were on the road once again on February 18. This time they traveled out to San Angelo and demonstrated for the Concho Valley Woodturners. They drove out on Friday and stayed with Bill and Sally King, who hosted and fed them very well. Saturday, February 19, was an all-day affair. In the morning Johnny demonstrated his Inside-Outside Christmas Ornaments.

There was a scrumptious lunch of brisket and all the trimmings with several

deserts. During the afternoon, Johnny discussed numerous topics including tool control, selection of tools, the Open Segmented Jig and the Stacy Hager line of home made tools which included the pointed skew, round skew, hacksaw parting tool and others. Some time was spent with questions and answers and individual hands-on experience under Johnny's practiced eye. There were 20 people present for the Saturday event and all seemed to enjoy the experience.

Thanks, Johnny and Marcia, for serving as such good ambassadors for woodturning and for CTWA.

Saturday, February 19, saw Betty and Stacey Hager off to Houston, where Stacey gave a slide talk on the golden mean to the Gulf Coast Woodturners. He discussed how the golden mean was derived, how it appears in nature and in classical design, as well as discussing its application in design today, including in woodturning. Thanks to Stacey and Betty for representing CTWA well. ***

Calendar

March 12 & 13, 2005 -- 8:30 AM to 4:30 PM
<i>Jamieson Demos - American YouthWorks</i>
March 14 & 15, 2005 -- 8:30 AM to 4:30 PM
<i>Jamieson Hands-On Sessions</i>
March 15, 2005 -- 7:00 to 9:00 PM
<i>CTWA Meeting - American YouthWorks</i>
April 2, 2005 -- 9:00 AM to 12:00 Noon
<i>First Saturday - Charlie Collins' Shop</i>
April 19, 2005 -- 7:00 to 9:00 PM
<i>CTWA Meeting - American YouthWorks</i>
May 7, 2005 -- 9:00 AM to 12:00 Noon
<i>First Saturday - Charlie Collins' Shop</i>
May 17, 2005 -- 9:00 AM to 12:00 Noon
<i>CTWA Meeting - American YouthWorks</i>

Lyle Jamieson Demos

Don't forget the Lyle Jamieson Demonstrations scheduled for Saturday and Sunday, March 12 and 13. The sessions will run from 8:30 AM until 4:30 PM at our regular meeting place, American YouthWorks. If you haven't signed up in advance, plan to come anyway. You can pay at the door. The cost is \$30 per day.

Although you can attend either day singly, the two days will be different. Topics will range from fundamentals of evaluating the log and tuning up the lathe to sharpening techniques, reverse chucking and bottom applications. Lyle will turn a natural edge bowl, mounting without a chuck, as well as turning a two-piece hollow form seed pot and a hollow form turned using his stabilizing handle.

Lyle asks that attendees bring the following to the sessions:

1. Two or three of your turned pieces for the Design Talk (he assures us that this is not a critique). He wants beginning, intermediate and advanced turnings, to talk about design.
2. Note taking materials
3. Camera, if you wish. He encourages picture taking.

Lyle likes to take a brief lunch break and begin again to give you a full-day program. On Saturday, we will have Subway sandwiches, chips, potato salad, brownies and drinks. On Sunday, we will have deli trays from HEB (to make your own sandwiches), coleslaw, chips, cookies and drinks. You will need to pay for these meals when you sign in on Saturday morning (\$15.00 -for two lunches). If you'd rather, you can bring your own lunch or go to one of the nearby eateries. We will have some light snacks and coffee and drinks available for break times.

See you there!



SWAT 2005

Call for Demonstrators

The Southwest Association of Woodturners is soliciting proposals from those interested in demonstrating at the 2005 SWAT Symposium in Wichita Falls, Texas, from September 30 through October 2, 2005. We have, in our southwest region, a vast amount of talent that should be shared with other woodturners.

If you are interested in demonstrating, please contact your chapter President Fred Stidman or SWAT Director Stacey Hager, or the SWAT web site, swaturners.com for an application form. This form should be completed and returned to the Demonstrator Selection Committee by April 30, 2004. Forms are also available from me directly.

Ken Terrell, Committee Chairman

19323 JoBar Dr.
Tyler, TX 75703

Phone 903.839.4735

E-mail kpterrell@cox.net ***

SWAT Newsletter Premiers

The SWAT Directors decided at their January meeting to institute a quarterly newsletter, to publicize the annual Symposium. As with **THE CHIP PILE**, the primary mode of distribution will be on the SWAT web site, swaturners.com, where you can download it, read it and print it if you desire. Hard copies are being distributed to sponsors and woodworking stores where SWAT member clubs are located.

I am serving as the Editor of the newsletter, SWAT Turnings, and the first issue went out on March 1. Check it out and give me your feedback on what else you would like to see in it.

Charlie Kay



Profiles

Lend me your tuxedo

If you are looking for something to do on Saturday, March 19, head down to San Marcos to catch the Heart of Texas Chorus at Evans Auditorium on the Texas State University campus. The show starts at 8:00 PM. The Heart of Texas

Chorus is composed of barbershop quartet singers and features our own woodturning baritone, **Craig Timmerman**. If you haven't seen them, try this event, as they put on quite a show. I'm sure that Craig can supply you with tickets, or you can order tickets by calling 866.801.4238 or by going to their web site at www.HOTchorus.org. Besides, you can tell the other folks that Craig is a pretty good singer for a woodturner!



E-mail

It is your responsibility to see that Membership Chairman **Drew Shelton** has your correct E-mail address. You can contact him at drew.shelton@sematech.org. We regularly use E-mail to advise members of important announcements on short notice. If Drew doesn't have your current E-mail address, we can't contact you.



Photo Credits

Photographs for this month's **CHIP PILE** were provided by **Drew Shelton, Jimmy Tolly** and **Charlie Kay**. If you have digital photos that you would like to have considered for use in the newsletter. Send them to the Editor at ckay@austin.rr.com.



The following turners have generously offered to open their shops and give their time to any member who wants to learn how to sharpen their tools, sharpen their skills, learn how to make a bowl or "test" the newest tool. Check out the people who bring items to Show and Tell. One trait common to all woodturners is that we all like to share, so just ask!

SOUTH

- Odie Bull** 512.442.2687
- Bill Hammack** 512.282.0832
- Stacey Hager** 512.282.1036
- Johnny Tolly** 512.858.4472
- Jimmy Tolly** 512.894.0686

NOTE: The Tolly brothers work strange shifts, so they may be available on times other than weekends.

- H. O. Evans** 512.282.2830

NOTE: He would like to confine his assistance to his specialty, segmented turnings.

NORTH

- Rusty Myers** 512.218.1606
- Frank Miller** 512.335.4768
- Judy Williams** 512.836.7897

ROUND ROCK

- Larry Walrath** 512.255.5379

LOCKHART/SAN MARCOS

- David Dick** 512.357.6517



March 5 saw some 12 to 14 folks at **Charlie Collins'** shop for a little turning and fellowship. **Jim Brinkman** was pushing candlesticks on his Carbatec, **Drew Shelton** was showing **Bill Hammack** how to turn an apple and **Frank Miller** was turning spindles. Several others tried their hands on the three available lathes. Another good day at the CTWA First Saturday. See you at the next one.



New members are welcome to join CTWA at any time. All you need is an interest in woodturning. CTWA membership also requires membership in the American Association of Woodturners (AAW). Local dues are \$25.00 per year, or \$2.10 per month prorated for new members joining during the year. AAW dues are \$40.00 per year for individuals and \$45.00 for families. For that you get a first class quarterly magazine, **American Woodturner**, with excellent articles on woodturning and woodturners, amply illustrated with photographs.

If you are interested in learning more about membership or want to join CTWA, contact our Membership Chairman:

Drew Shelton
 112 Oakland Drive
 Georgetown, TX 78628
 512.863.4651
 drew.shelton@sematech.org

This Editor's Desk column is going to be a little different from those I have written in the past. Several of you have asked me for construction details on the portable stand that I built for my Jet mini-lathe. You've also asked me for drawings, on the misguided assumption that this old right-brained guy would

actually make some detailed drawings before he began to build something! At

best, I make a bit of sketch and pencil in a few key measurements, where size might be important. The rest of it is just cut and fit.

When I bought my Jet, I wanted an easily portable base that would include some storage space for lathe accessories and break down so that it would be easy for an old guy with a questionable back to load it in the back of his truck. I spent some time on the net and in the turning and wood-working magazines, looking for designs to no avail. If anyone had any good designs, they were keeping them to themselves.

I checked out the boxes that Jim Brinkman and others had mounted their Carbatecs to and proceeded to go from there.

I decided to build a base with a tray that would hold a separate box. Thus when I loaded it up, I could load the base, the box and the lathe separately. The top of the box would hold the lathe and the box would contain a couple of drawers, sealed as best I could to keep most of the chips and dust out.

Three or four critical dimensions went onto my rough sketch. I wanted the spindle height to be the same as my Woodfast, the top of the base had to be big enough to support my Jet and I wanted the drawers to be deep enough



to contain my Vicmarc chuck when it was off the lathe. The rest of the dimensions would largely be determined by what I could find in my scrap



the size of the scrap I found for it. I drilled four 1" holes, 1/8" deep in the top to precisely match the four rubber feet on the bottom of the lathe, to prevent it from walking around without having to fasten it in place. The drawer sides and bottoms were from scraps of 1/2" birch plywood, to keep the weight

down. I made the drawer pulls out of some scraps of maple wine glass hanging strips that I had on hand. I ripped one wing off and rounded over that edge and screwed them in place.

The bottom of the tray, which screws to the base, was made of a scrap of 3/4" construction plywood. The tray has pieces of 1 1/2" wide, 3/4" birch plywood around it to form rails to keep the box in place. The base was built out of pieces of recycled 2X4 and 2X6 lumber that I had on hand. The edges of all of the base pieces, the tray rim and the top of the box were all rounded over using a router.



The drawers, the box and base tray were assembled with glue and my pneumatic brad gun. Everything is butt jointed to keep it simple.

The base is

glued and screwed together and the tray is screwed to it. The top of the box is screwed in place without glue, in case I needed to take it apart to get to the drawers.

I built the box and the drawer fronts from some scraps of 3/4" Baltic birch plywood, and the final size of the top depended on

Included with this article are some photos showing some details of the construction. In addition, I have spared no expense in preparing some very mediocre



dimensioned sketches. If anyone wants more details, you can contact me and I will get them to you. I've limited the

number of sketches I have included here in the interests of brevity.

As always, there are some things that I would do differently if I were doing it again. The biggest of these would be to make the front edge of the box top overhang the drawer front by at least 3/4", rather than ending flush with it. That would make it easier to keep from dropping chips in the drawer every time you open it. Since I wanted to photograph the details of the drawer construction, I went ahead and unscrewed the top. Now I'll make a new top and put it on.



Keep learning and keep turning.

Charlie Kay

PS: For those of you that don't read your E-mail, my new phone number is 512.295.2144. ☆☆☆

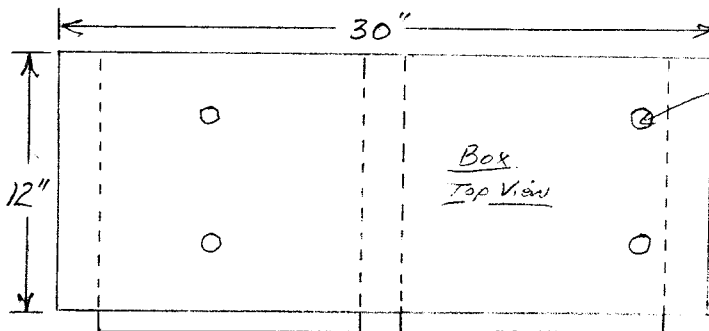

1" ϕ
1/2" deep
recesses
(matches
rubber feet
on lathe)

Box
3/4" Baltic Birch Plywood
butt jointed

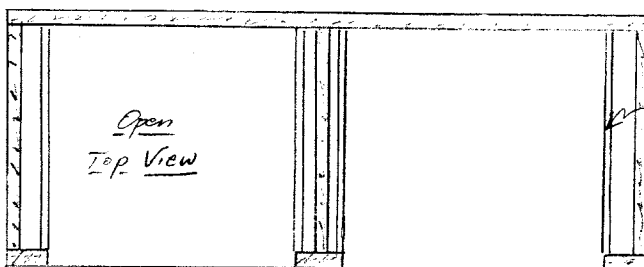
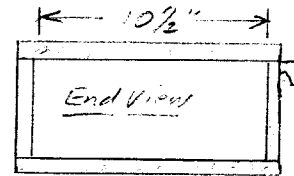
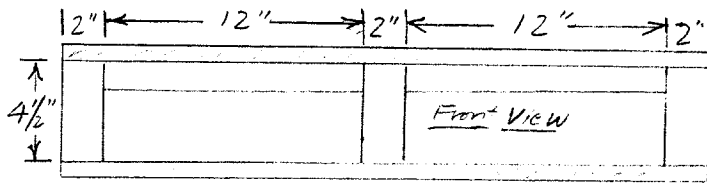

3/8" x 3/8"
strips used
as
drawers
guides

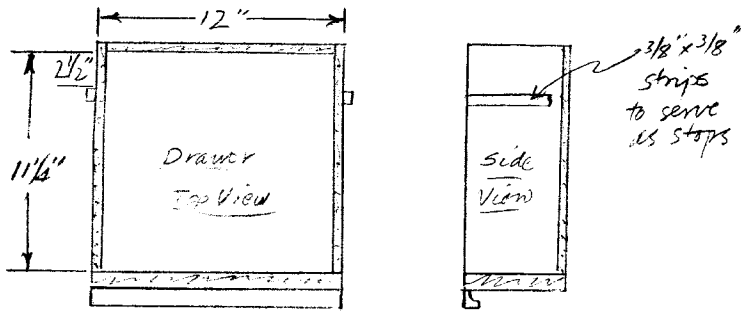

Drawers
 3/8" Baltic Birch plywood
 sides & bottom
 3/4" Baltic Birch Fronts
 butt jointed

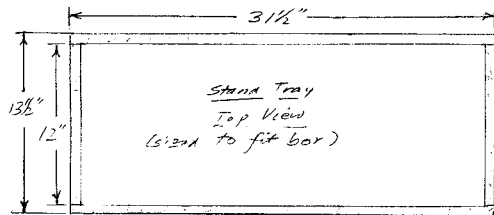
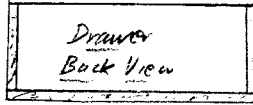

Stand Tray
 3/4" plywood
 (screws to base)

Base
 legs are 2x6's
 other pieces 2x4's
 (screwed together)

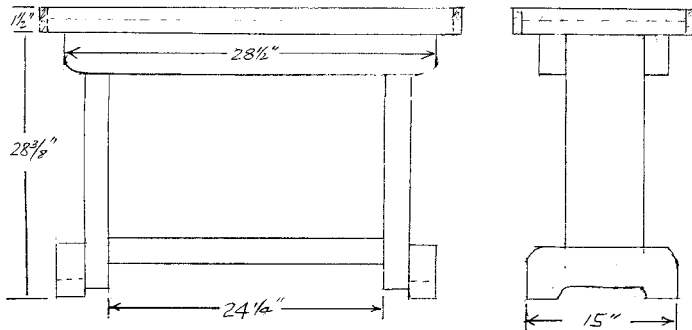

Classified Ads

Free personal classified ads are available to all members of CTWA to sell, buy or trade woodworking related items. To place an ad, contact Charlie Kay at 512.295.2144 or via E-mail at ckay@austin.rr.com. Ads will be run for two months and then dropped.

FOR SALE: Powermatic Model 45. Old, but in good working order. Variable speed, one HP, 12x36, heavy (about 400 lb.). Comes with faceplates, drive center, live center, etc. Will help you deliver. \$700.

Oneway tailstock live center system. MT2. \$50.

Call Len Brissette at 512.423.3625, or E-mail at mesquite@tex-as.net.

FOR SALE: Grizzly 12" surface planer. Runs great. Newly sharpened blades and extra set of blades included. Has 4" dust collector chute. \$125.00. Call Jim Brinkman at 512.258.4732 or E-mail at jsbrink@attglobal.net.

FOR SALE: Woodfast shortbed lathe, 20" throw, 16" centers, 1.5 HP variable speed with reverse. Includes face plate, wrenches, tool rest, spur drive, live center. This lathe is in excellent condition and both motor and controller are brand new. Listed at \$3,400 in last year's Craft Supplies catalog. Will sell for \$1,700 and help you deliver.

Detail Master Dagger III wood burner power supply. Sells for \$143 at Woodcraft. Will sell for \$75.

Jet JWP-12 portable surface planer, with extra set of new knives. Good shape. \$120.

Call Charlie Kay at 512.295.2144 or E-mail at ckay@austin.rr.com

Author

CTWA turner and tool maker, **Stacey Hager**, seems to have found his rhythm as an author. You will recall that the Spring 2004 **American Woodturner** had Stacey's article, "The Hager Parting Tool." Somehow he missed the summer issue and fall issues, but he is back in the latest, Spring 2005 issue of **American Woodturner** with "The Cove Tool." Congratulations to Stacey on two jobs well done. If you haven't read the articles yet, check them out. ❄❄❄

Meeting Location

The CTWA meets at American Youth-Works, 1901 East Ben White Boulevard (Texas 71) in south Austin. The building is on the south side of Ben White, just east of Interstate 35. The best entry is off Woodward Street, just south of a little strip center. You enter an alleyway into a lighted parking lot. We will enter through the back door. As you drive in, you will see a truck dock in the back of the building with a big roll-up white door. The entryway is just to the right of the truck dock. Because of the construction at Ben White and I-35, folks from the north may want to exit I-35 at Woodward and proceed south on Woodward across Ben White. Folks from the south might do better to go east on St. Elmo, then north on Woodward. Those coming from the west on Ben White will just have to fight their way through until the construction is finished. See you at the meeting.

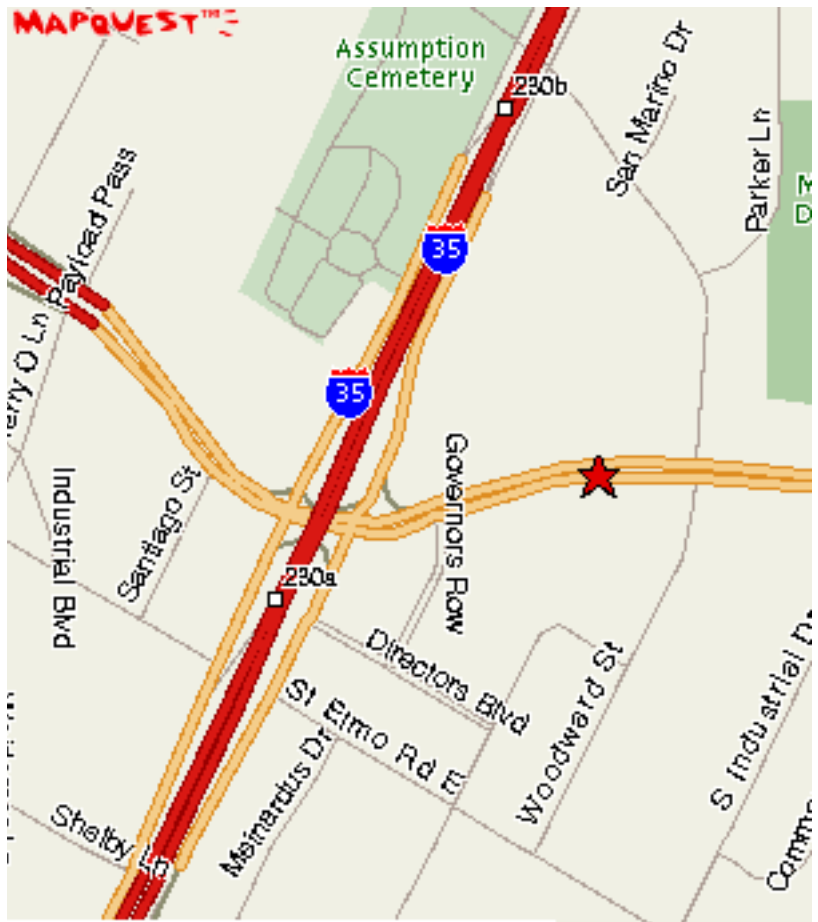

THE CHIP PILE
CENTRAL TEXAS WOODTURNERS ASSOCIATION

Charles Kay, Editor
100 Matzig Cove
Buda, TX 78610-3108

To: